

# ***BT-H<sub>2</sub>FOG***

**WATER-BASED LOW-FOG MACHINE**

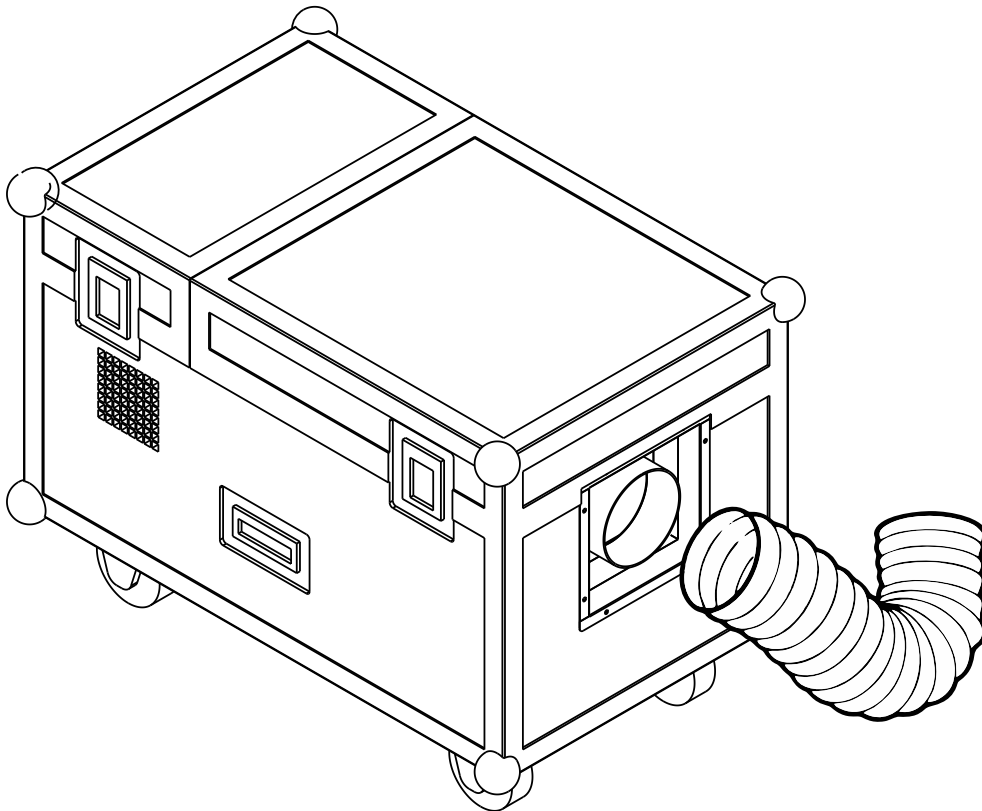

## **ENGLISH**

### **Operation Manual**

Other languages can be downloaded from:  
[WWW.BRITEQ-LIGHTING.COM](http://WWW.BRITEQ-LIGHTING.COM)



*Version: 1.0*





### **EN - DISPOSAL OF THE DEVICE**

Dispose of the unit and used batteries in an environment friendly manner according to your country regulations.

### **FR - DÉCLASSER L'APPAREIL**

Débarrassez-vous de l'appareil et des piles usagées de manière écologique Conformément aux dispositions légales de votre pays.

### **NL - VERWIJDEREN VAN HET APPARAAT**

Verwijder het toestel en de gebruikte batterijen op een milieuvriendelijke manier conform de in uw land geldende voorschriften.

### **DU - ENTSORGUNG DES GERÄTS**

Entsorgen Sie das Gerät und die Batterien auf umweltfreundliche Art und Weise gemäß den Vorschriften Ihres Landes.

### **ES - DESHACERSE DEL APARATO**

Reciclar el aparato y pilas usadas de forma ecologica conforme a las disposiciones legales de su país.

### **PT - COMO DESFAZER-SE DA UNIDADE**

Tente reciclar a unidade e as pilhas usadas respeitando o ambiente e em conformidade com as normas vigentes no seu país.

# OPERATION MANUAL

Thank you for buying this Briteq® product. To take full advantage of all possibilities and for your own safety, please read these operating instructions very carefully before you start using this unit.

## FEATURES

- Ultrasonic 1500W Low Fog machine in flight case.
- Two powerful ultrasonic elements convert the combination of smoke fluid and distilled water into a large amount of beautiful low-lying fog.
- No more hassle with expensive and hard to find CO<sub>2</sub> dry ice !
- Low-noise operation: perfect for use in theatres, TV-studios, ...
- The black hose is equipped with a "fast click-on" system to significantly reduce installation time!
- Adjustable fog output and fan speed:
  - Via 2 DMX channels
  - Via the on board control panel with LCD-display and timer
- Stainless steel "304" water tank (instead of ordinary treated iron) to avoid rust!
- Prepared for wireless DMX: just plug-in an optional WTR-DMX DONGLE ! (Briteq® code: 4645)
- Original Neutrik® PowerCON and 3-pin DMX connectors for input and output
- Strong flight case, equipped with recessed flip handles and 4 soft rubber casters with brakes.

## BEFORE USE

- Before you start using this unit, please check if there's no transportation damage. Should there be any, do not use the device and consult your dealer first.
- **Important:** This device left our factory in perfect condition and well packaged. It is absolutely necessary for the user to strictly follow the safety instructions and warnings in this user manual. Any damage caused by mishandling is not subject to warranty. The dealer will not accept responsibility for any resulting defects or problems caused by disregarding this user manual.
- Keep this booklet in a safe place for future consultation. If you sell the fixture, be sure to add this user manual.

### Check the contents:

Check that the carton contains the following items:

- Operating instructions
- Power cable
- BT-H2FOG
- Flexible output hose

## SAFETY INSTRUCTIONS:



**CAUTION**  
RISK OF ELECTRIC SHOCK  
DO NOT OPEN



**CAUTION:** To reduce the risk of electric shock, do not remove the top cover. No user-serviceable parts inside. Refer servicing to qualified service personnel only.



The lightning flash with arrowhead symbol within the equilateral triangle is intended to alert the user or the presence of un-insulated "dangerous voltage" within the product's enclosure that may be of sufficient magnitude to constitute a risk of electric shock.



The exclamation point within the equilateral triangle is intended to alert the user to the presence of important operation and maintenance (servicing) instructions in the literature accompanying this appliance.



This symbol means: indoor use only.



This symbol means: Read instructions.

- To protect the environment, please try to recycle the packing material as much as possible.
- To prevent fire or shock hazard, do not expose this appliance to rain or moisture.
- To avoid condensation to be formed inside, allow the unit to adapt to the surrounding temperatures when bringing it into a warm room after transport. Condense sometimes prevents the unit from working at full performance or may even cause damages.
- This unit is for indoor use only.
- Don't place metal objects or spill liquid inside the unit. Electric shock or malfunction may result. If a foreign object enters the unit, immediately disconnect the mains power.
- Locate the unit in a well ventilated spot, away from any flammable materials and/or liquids.
- Don't cover any ventilation openings as this may result in overheating.
- Prevent use in dusty environments and clean the unit regularly.
- Keep the unit away from children.
- Inexperienced persons should not operate this device.
- Maximum safe ambient temperature is 40°C. Don't use this unit at higher ambient temperatures.
- The units' surface temperature may reach up to 85°C. Don't touch the housing with bare hands during its operation.
- Make sure to always place the unit on a stable surface, never install the fogger above the audience, a little liquid can always drip from the fog output.
- Allow the device about 10 minutes to cool down before you start servicing.
- Always unplug the unit when it is not used for a longer time or before you start servicing.
- Check that the available voltage is not higher than the one stated on the rear panel of the unit.
- The power cord should always be in perfect condition. Switch the unit immediately off when the power cord is squashed or damaged. It must be replaced by the manufacturer, its service agent or similarly qualified persons in order to avoid a hazard.
- Never let the power-cord come into contact with other cables!
- This unit must be earthed in order comply with safety regulations.
- In order to prevent electric shock, do not open the cover.
- **Never** repair a fuse or bypass the fuse holder. **Always** replace a damaged fuse with a fuse of the same type and electrical specifications!
- In the event of serious operating problems, stop using the fixture and contact your dealer immediately.
- The housing must be replaced if they are visibly damaged.
- Please use the original packing when the device is to be transported.
- Due to safety reasons it is prohibited to make unauthorized modifications to the unit.

**DESCRIPTION:**

The BT-H2FOG comes in a flight case with an upper lid that can be opened in 2 parts to have easy access to the 2 main compartments.

1. **WATER TANK COMPARTMENT:** this is the big water tank where 2 powerful piezo elements are mounted on the bottom.
2. **FOG FLUID + CONTROL COMPARTMENT:** here you can find:
  - **Fog fluid tank:** The fog fluid tank should be filled up with standard fog fluid. Attention: don't spill liquid in the container compartment; it could seep through and damage the electronics.
  - **Control panel:** used to set up the machine or control it manually, see further.

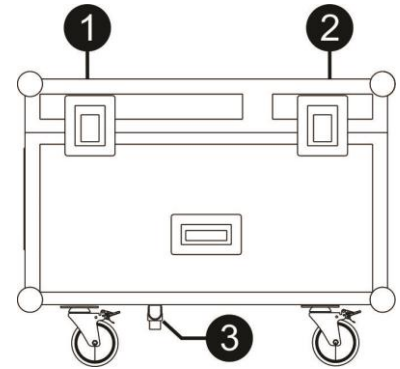

3. **WATER EVACUATION TAP:** used to drain the water tank. Don't forget to close it when you fill up the tank ☺
4. **DMX INPUT:** male 3pin XLR-connector used to connect the unit with the DMX controller or with the previous unit in the DMX chain.
5. **DMX OUTPUT:** female 3pin XLR-connector used to connect the unit with the next unit in the DMX chain.
6. **POWER SWITCH:** Used to switch the unit on/off.
7. **AUTOMATIC CIRCUIT BREAKER:** if this beaker fails, please inspect the unit well before you press the breaker to re-activate it again. If the problem occurs again, stop using the machine and bring it in for technical repair.
8. **MAINS INPUT:** connect the supplied PowerCON mains cable here. The cable should be plugged in a mains wall socket with earth connection.
9. **WATER LEVEL [OK] LED:** indicates there is still enough water in the water tank to run the machine.

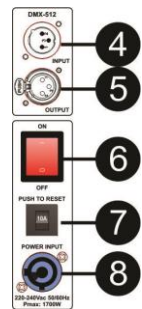

10. **WATER LEVEL [MIN] LED:** indicates the water level in the tank is too low. The unit will stop working until the tank is filled up again. (PS: no need to add salt each time)
11. **DMX LED:** this indicator is lit while a valid DMX-signal is detected. (wired or wireless DMX)
12. **[MENU] Button:** used to browse the setup menu (see next chapter)
13. **[TIMER/▲] Button:** used to increase the value of the selected parameter or to activate the timer of the unit. The fogger will work automatically.
14. **[VOLUME/▼] Button:** used to decrease the value of the selected parameter or switch the output manually on.
15. **[STOP] Button:** used to stop the timer or manual operation of the fogger.

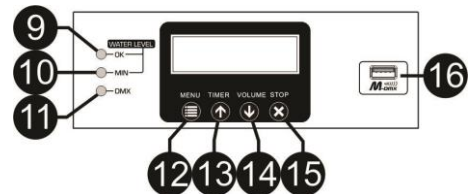

16. **M-DMX INPUT:** Please note that this USB-connector is NOT used for firmware updates or to connect the unit to a PC! Instead this USB-connector makes it very easy to add wireless DMX to the unit! Just add the (optional) WTR-DMX DONGLE from BRITEQ® and you will get wireless DMX! Moreover you will be able to connect other DMX-controlled equipment to the DMX-output so you can share the wireless DMX function with all connected units! No extra settings to be made in the setup menu, just follow the procedure in the user manual supplied with the WTR-DMX DONGLE from BRITEQ®. The separate WTR-DMX DONGLE is available from [WWW.BRITEQ-LIGHTING.COM](http://WWW.BRITEQ-LIGHTING.COM) (order code: 4645)

17. **AIR INTAKE:** do not cover these air intakes. Make sure they cannot soak up dirty or polluted air.
18. **HOSE WITH FAST COUPLER:** the fogger comes with an extendable PVC hose to evacuate the produced low fog. The hose is fixed to the fogger with a very easy "twist and click" bayonet coupler. Simply stretch the hose out and place it on the floor so that the low fog can flow over the stage.

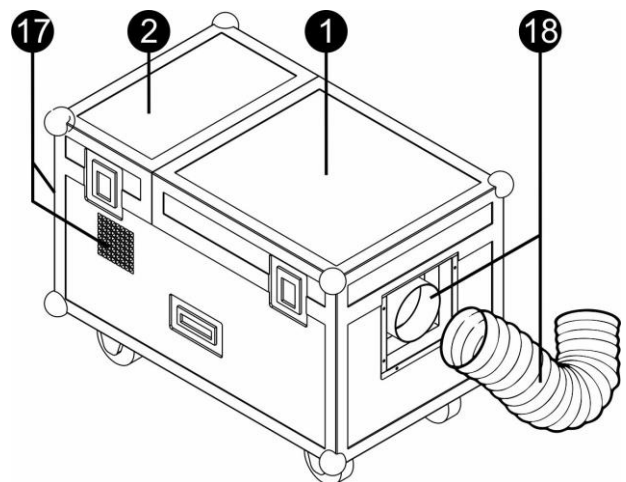

## OPERATING INSTRUCTIONS

### !!! IMPORTANT !!!

The water tank **MUST** be filled with water before use: see previous chapter!

It is highly recommended to use decalcified or distilled water!

The markings for min/max water levels must be respected!

► Empty the water tank and fog liquid tank before each transport and after each use ◀

- Put the fogger on a flat and very stable surface and activate the brakes on the wheels.
- Use standard fog liquid to fill up the fog fluid canister. Close the canister immediately to prevent dirt to enter the reservoir!
- Fill up the big water tank with distilled or decalcified water. On the inside of the tank there are several level indications: fill the tank until the water level is between the minimum and maximum lines. (+/- 10 to 15 liters).

**IMPORTANT: Add +/-2 tablespoons of kitchen salt and stir the water by hand firmly to distribute the salt well.**

The water level indicators (9+10) will turn from [MIN] to [OK]

- Connect the fogger to a mains wall socket with earth connection
- Switch the fogger on and wait for about 2 to 3 minutes. (warm up time)
- You can now use the machine via the build-in timer or it can be controlled by DMX. (see below)

### Setup menu

The setup menu is used to adjust the different parameters of the fogger.

The [MENU] button is used to browse the options of the setup menu:

- [DMX512 Add]** press the ▲/▼-buttons (13+14) to adjust the DMX-address.
- [FAN SPEED xxx%]** press the ▲/▼-buttons (13+14) to adjust the fan speed (1-100%) while the fogger is used in manual or in timer mode.
- [VOLUME OUT xxx%]** press the ▲/▼-buttons (13+14) to adjust the output volume (1-100%) while the unit is used in manual / timer mode.
- [INTERVAL SET xxxs]** press the ▲/▼-buttons (13+14) to adjust the interval time (10s→200s) while the fogger is used in timer mode.
- [DURATION SET xxxs]** press the ▲/▼-buttons (13+14) to adjust the fog duration time (10s→100s) while the fogger is used in timer mode.

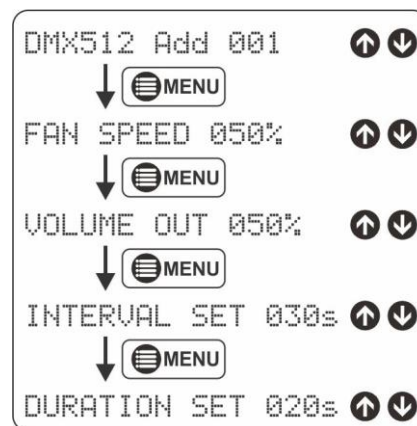

### Controlled via DMX:

- Connect the unit to the DMX-line or use the WTR-DMX DONGLE for a wireless DMX setup.
- The DMX led (11) should be lit to indicate that a DMX-signal is received.
- Press the [MENU] button until the DMX address appears on the display
- Use the ▲/▼ buttons to set the desired DMX address.
- The unit uses 2 DMX channels:
  - **Channel 1:** fan speed (000-005: fan off 006-255: fan speed 1→100%)
  - **Channel 2:** volume control (000-005: no output 006-255: volume 1→100%)

### Controlled via the internal timer:

In this mode the fogger is not connected to a DMX-controller.

- First set the fan speed, volume, interval & duration time (see “setup menu” points B to E)
- Press the [X STOP]-button (15) to be sure that the fogger is in STOP mode.
- Press the [TIMER/▲]-button (13) to start the timer function.
- Press the [X STOP]-button (15) to stop the timer function.

### Manual Control:

In this mode the fogger is not connected to a DMX-controller.

- First set the fan speed & output volume (see “setup menu” points B to C)
- Press the [X STOP]-button (15) to be sure that the fogger is in STOP mode.
- Press the [VOL/▼]-button (14) to start the manual working mode.
- Press the [X STOP]-button (15) to stop the manual working mode.

## TRANSPORT INSTRUCTIONS

- Always empty the big water tank before transport: open the water evacuation tap (3) on the bottom of the fogger.
- When the water tanks is empty: put the extendable PVC-hose in the big water tank.
- To avoid spilling fog fluid: make sure that the fog liquid canister is not more than half full during transport.
- Close the top lid of the flight case and unlock the wheel brakes.
- Put the flight case in the truck but **DO NOT TIP THE FLIGHT CASE !!!**
- Always lock the brakes during transport!!!

## MAINTENANCE

- **IMPORTANT:** Always set the output to Zero and wait for minimum 30 seconds before to switch off the unit. This allows the unit to execute its cleaning process so all the remaining fluid is removed from the internal circuits..
- Switch off the unit, unplug the mains cable and wait until the unit has been cooled down.

### During inspection the following points should be checked:

- All screws used for installing the device and any of its parts should be tightly fastened and may not be corroded.
- Housings, fixations and installations spots (ceiling, truss, suspensions) should be totally free from any deformation.
- The mains cables must be in impeccable condition and should be replaced immediately when even a small problem is detected.

**Attention: We strongly recommend internal cleaning to be carried out by qualified personnel!**

## SPECIFICATIONS

This unit is radio-interference suppressed. This product meets the requirements of the current European and national guidelines. Conformity has been established and the relevant statements and documents have been deposited by the manufacturer.

<b>Mains Input:</b>	AC 220-240V, 50/60Hz
<b>Power consumption:</b>	1750 Watt
<b>DMX Channels:</b>	2
<b>Fuse:</b>	10A
<b>Warm up time:</b>	3.5 min
<b>Fog liquid tank:</b>	2.5L
<b>Max output:</b>	+/- 11'000 cfm
<b>Water tank:</b>	+/- 10 liters
<b>Fog liquid consumption:</b>	1-40 ml/min
<b>Recommended Fluid:</b>	Standard fog fluid
<b>Dimensions (L x W x H):</b>	750 x 445 x 550 mm (including wheels – see drawing)
<b>Weight:</b>	39 kg

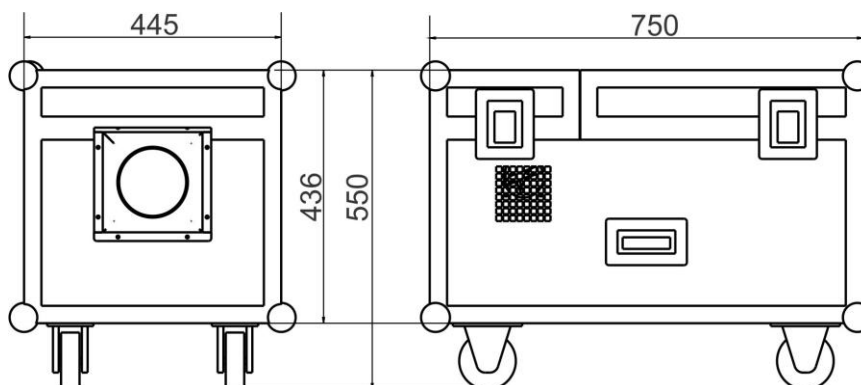

All the information is subject to change without prior notice

You can download the latest version of this user manual on our website: [www.briteq-lighting.eu](http://www.briteq-lighting.eu)



## MAILING LIST

**EN: Subscribe today to our mailing list for the latest product news!**

**FR: Inscrivez-vous à notre liste de distribution si vous souhaitez suivre l'actualité de nos produits!**

**NL: Abonneer je vandaag nog op onze mailinglijst en ontvang ons laatste product nieuws!**

**DE: Abonnieren Sie unseren Newsletter und erhalten Sie aktuelle Produktinformationen!**

**ES: Suscríbete hoy a nuestra lista de correo para recibir las últimas noticias!**

**PT: Inscreva-se hoje na nossa mailing list para estar a par das últimas notícias!**

**[WWW.BRITEQ-LIGHTING.COM](http://WWW.BRITEQ-LIGHTING.COM)**

**Copyright © 2018 by BEGLEC NV**

't Hofveld 2C ~ B1702 Groot-Bijgaarden ~ Belgium

Reproduction or publication of the content in any manner, without express permission of the publisher, is prohibited.